



*Up-to-date Questions and Answers from authentic resources to improve knowledge and pass the exam at very first attempt. ----- Guaranteed.*



920-805 Dumps  
920-805 Braindumps  
920-805 Real Questions  
920-805 Practice Test  
920-805 Actual Questions



[killexams.com](http://killexams.com)

**Nortel**

**920-805**

*Nortel Data Networking Technology*

ORDER FULL VERSION

<https://killexams.com/pass4sure/exam-detail/920-805>



Rapid Spanning Tree Protocol was created to help to overcome the slow convergence time of 802.1D Spanning Tree. Which statement about Rapid Spanning Tree Protocol is false?

- A. It changes path costs.
- B. It uses designated forwarding ports.
- C. It decreases the number of port states.
- D. It does not block ports like Spanning Tree Protocol does.

**Answer:** D

**QUESTION:** 57

Click on the exhibit button.

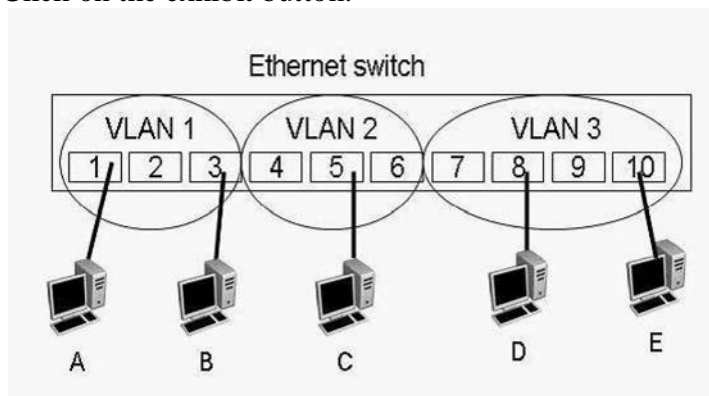

The Ethernet Switch has three port-based VLANs. Ports 1-3 are in VLAN 1. Ports 4-6 are in VLAN 2. Ports 7-10 are in VLAN 3. PC A sends a broadcast packet. Which PCs will see the broadcast?

- A. Port 3 on PC B
- B. Ports 5, 6 on PC C
- C. Port 8 on PC D
- D. Ports 9, 10 on PC E

**Answer:** A

**QUESTION:** 58

Some Nortel Ethernet Switches and Ethernet Routing Switches use an alternate frame processing method that allows you to configure four different Ethernet egress options. One of these options is Untag PVID only. Which statement best describes this option?

- A. All frames that exit the port will be tagged.
- B. All frames that exit the port will be untagged.
- C. All frames that are on the same VLAN as the egress port VLAN ID will be tagged, and all others will be untagged.
- D. All frames that are on the same VLAN as the egress port VLAN ID will be untagged, and all others will be tagged.

**Answer:** D

**QUESTION:** 59

With respect to the function of the IEEE 802.1s Multiple Spanning Tree Protocol (MSTP), which statement is false?

- A. MSTP creates a separate spanning tree group for each VLAN.
- B. Each VLAN runs the Spanning Tree algorithm only within the VLAN.
- C. The MSTI messages allow each spanning tree group to support multiple VLANs.
- D. The default spanning tree group in MSTP is called the Common and Internal Spanning Tree (CIST).

**Answer:** B

**QUESTION:** 60

Occasionally, a switch will receive frames faster than it can process them. The buffers on the switch become congested, and the switch begins to discard incoming frames because it has no place to store them. If 802.3x flow control is supported, what is the resultant behavior in a congestion situation?

- A. Switches become overloaded.
- B. Switch buffer congestion results.
- C. The receiving switches send pause frames to slow incoming traffic.
- D. The receiving switches discard frames until the overloaded condition is resolved.

**Answer:** B

**QUESTION:** 61

An Ethernet switch connects to the core switch with two fiber ports in a link aggregation group created through LACP. One of the fiber connections was damaged, and the network administrator wants to create a link aggregation group with the remaining fiber

link and two of the copper ports. Which constraint on the link aggregation group must the administrator be aware of?

- A. Links in a link aggregation group may combine multiple speeds and media types.
- B. Links in a link aggregation group must operate at the same speed and use the same media type.
- C. Links in a link aggregation group must use the same speed, but can combine multiple media types.
- D. Links in a link aggregation group must use the same media type, but can combine multiple speeds.

**Answer:** B

**QUESTION:** 62

Click on the exhibit button.

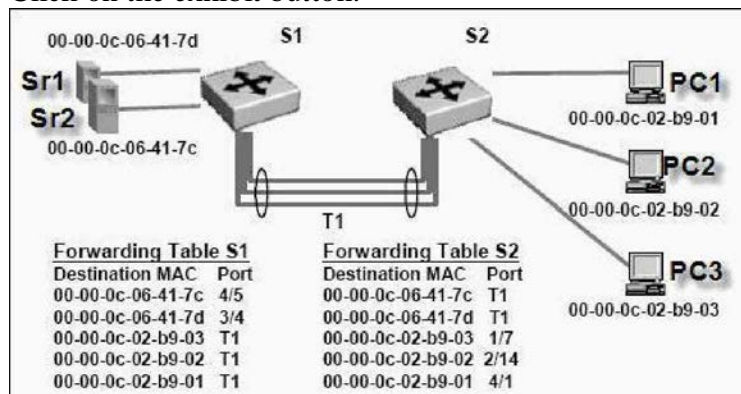

PC1 sends a packet to Srv2. The destination address for the frame is 00-00-0c-06-41-7c. If the address was not in the forwarding database of switch 2, how would the switch 2 treat the packet?

- A. Switch 2 would arp to find Srv2.
- B. Switch 2 would drop the packet.
- C. Switch 2 would flood the packet out all ports.
- D. Switch 2 would forward the packet out T1, because that is its default route.

**Answer:** C

**QUESTION:** 63

Click on the exhibit button.

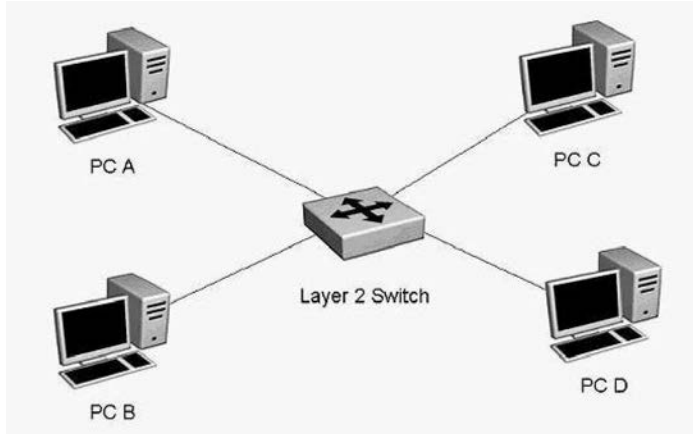

Four PCs are connected to a switch. PC A needs to communicate with PC D. Which statement is false?

- A. If PC D sends a unicast packet to PC A, PC B and PC C will not see traffic.
- B. If PC A sends a unicast packet to PC D, PC B and PC C will see traffic.
- C. If PC A issues an ARP to discover the MAC address of PC D, PC B and PC C will see traffic.
- D. If PC A sends a unicast packet to PC D, PC B and PC C will not see traffic.

**Answer: B**

# SAMPLE QUESTIONS



*These questions are for demo purpose only. **Full version** is up to date and contains actual questions and answers.*

*Killexams.com is an online platform that offers a wide range of services related to certification exam preparation. The platform provides actual questions, exam dumps, and practice tests to help individuals prepare for various certification exams with confidence. Here are some key features and services offered by Killexams.com:*



**Actual Exam Questions:** *Killexams.com provides actual exam questions that are experienced in test centers. These questions are updated regularly to ensure they are up-to-date and relevant to the latest exam syllabus. By studying these actual questions, candidates can familiarize themselves with the content and format of the real exam.*

**Exam Dumps:** *Killexams.com offers exam dumps in PDF format. These dumps contain a comprehensive collection of questions and answers that cover the exam topics. By using these dumps, candidates can enhance their knowledge and improve their chances of success in the certification exam.*

**Practice Tests:** *Killexams.com provides practice tests through their desktop VCE exam simulator and online test engine. These practice tests simulate the real exam environment and help candidates assess their readiness for the actual exam. The practice tests cover a wide range of questions and enable candidates to identify their strengths and weaknesses.*

**Guaranteed Success:** *Killexams.com offers a success guarantee with their exam dumps. They claim that by using their materials, candidates will pass their exams on the first attempt or they will refund the purchase price. This guarantee provides assurance and confidence to individuals preparing for certification exams.*

**Updated Content:** *Killexams.com regularly updates its question bank and exam dumps to ensure that they are current and reflect the latest changes in the exam syllabus. This helps candidates stay up-to-date with the exam content and increases their chances of success.*

**Technical Support:** *Killexams.com provides free 24x7 technical support to assist candidates with any queries or issues they may encounter while using their services. Their certified experts are available to provide guidance and help candidates throughout their exam preparation journey.*

For More exams visit <https://killexams.com/vendors-exam-list>  
*Kill your exam at First Attempt....Guaranteed!*